

Cabinet free drive technology

Motor integrated drive IndraDrive Mi - KSM



Cabinet free drive technology

Motor integrated drive ■ IndraDrive Mi - KSM

Documentation



- Multi-Ethernet communication for a variety of automation environments
- Multi-Ethernet output to connect distributed peripherals
- Safe Torque Off (STO) function, including the easy creation of safety zones and SafeMotion
- Comprehensive firmware options (integrated motion logic, etc.)
- Various mechanical designs

With KSM, the motor integrated drive series of IndraDrive Mi, Rexroth introduces another milestone in drive technology – electronic control system and servo motor combined in one ultra-compact unit.

This makes IndraDrive Mi the ideal solution for all applications where maximum flexibility and economic efficiency should come along with minimum space requirements.

In addition to its compact design, KSM combines the best characteristics of an IndraDrive and MSK servo motor – from the drive-integrated PLC according to IEC 61131-3 and safety technology up to protection category IP65.

Technical data**Electrical data**

Type	Maximum speed	Torque at standstill	Maximum torque	Continuous current at standstill	Maximum current	Moment of inertia
	n Max	M 0	M Max	I 0	I Max	J
	[1/min]	[Nm]	[Nm]	[A]	[A]	[kgm ²]
KSM02.1B-041C-42	5500	2.2	9.4	1.5	6.8	0.00017
KSM02.1B-061C-35	4300	6	25	3.3	14.9	0.00087
KSM02.1B-061C-61	6000	5.5	18	5.2	17.7	
KSM02.1B-071C-24	3400	10.5	35	4.6		0.00173
KSM02.1B-071C-35	4700	10	28	6		
KSM02.1B-076C-35		8.7	29	5.2	0.0043	

Dimensions

Cabinet free drive technology

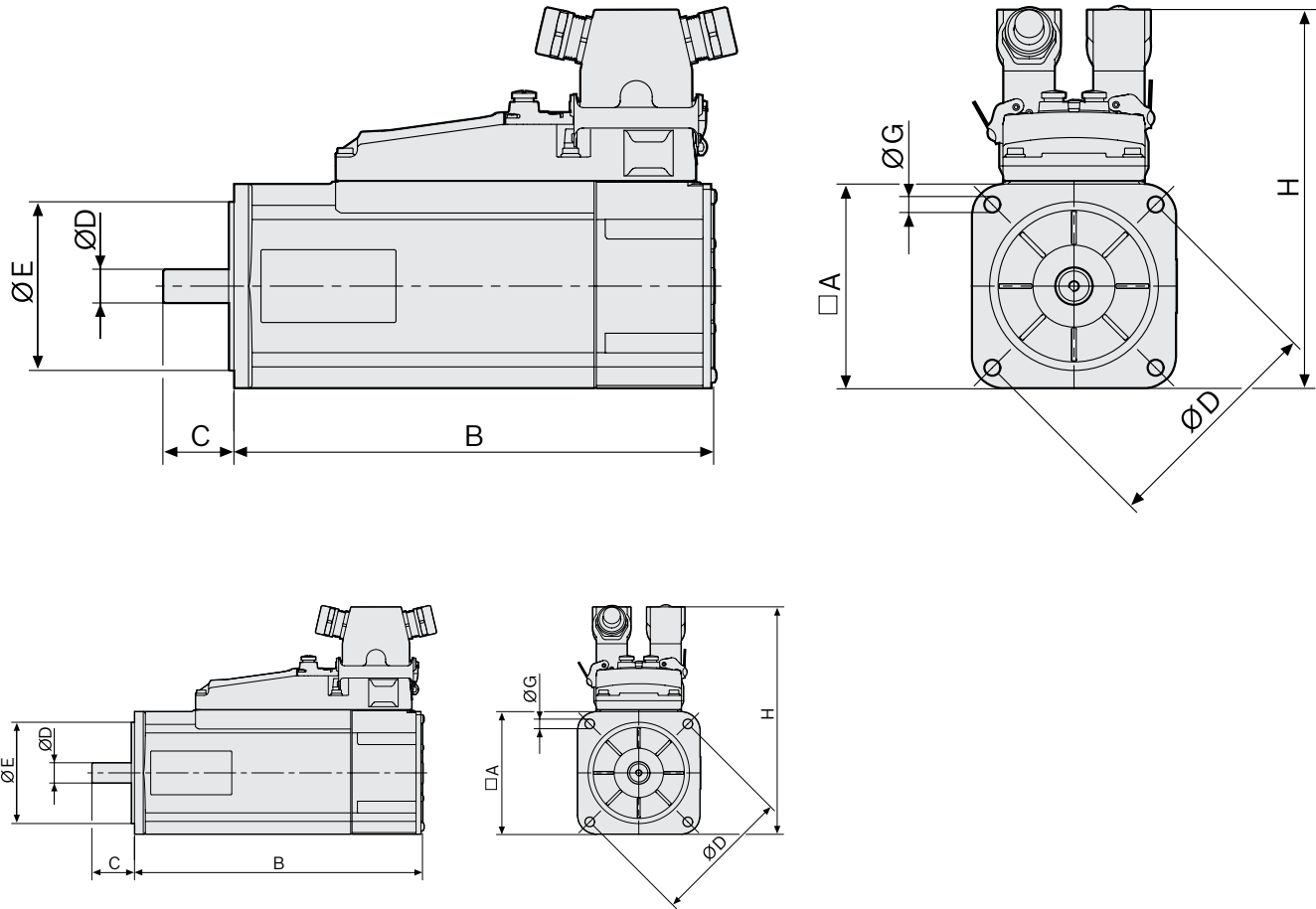
Motor integrated drive ■ IndraDrive Mi - KSM

Type	A	B	C	Ø D	Ø E	Ø F	Ø G	H	Mass
	[mm]	[mm]	[mm]	[mm]	[mm]	[mm]	[mm]	[mm]	[kg]
KSM02.1B-041C-42	82	252	30	14	50	95	6.6	194	5.6
KSM02.1B-061C-35	115	271	40	19	95	130	9	219	9.6
KSM02.1B-061C-61									
KSM02.1B-071C-24	140	307	58	32	130	165	11	247	14.1
KSM02.1B-071C-35									
KSM02.1B-076C-35									14.6

Components

Cabinet free drive technology

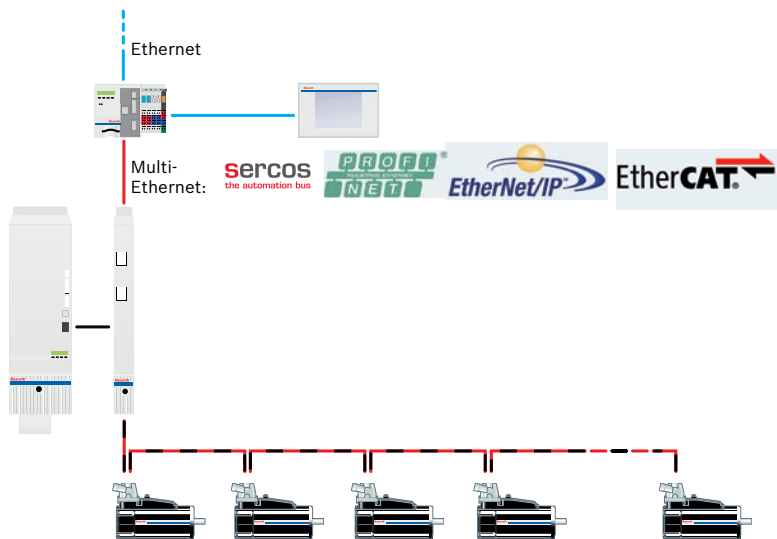
Motor integrated drive ■ IndraDrive Mi - KSM

Servo drives

Description	Page	Details
Converters	IndraDrive C	HCS02
Converters	IndraDrive C	HCS03
Modular system	Power supplies	IndraDrive M - HMV
Cabinet free drive technology	Near motor drive	IndraDrive Mi - KMS
Cabinet free drive technology	Drive connection box	IndraDrive Mi - KCU

Bosch Rexroth AG

Postfach 13 57
97803 Lohr, Germany
Bgm.-Dr.-Nebel-Str. 2
97816 Lohr, Germany
Tel. +49 9352 18-0
Fax +49 9352 18-8400
www.boschrexroth.com/electrics

Local contact information can be found at:

www.boschrexroth.com/adressen

The data specified above only serve to describe the product. As our products are constantly being further developed, no statements concerning a certain condition or suitability for a certain application can be derived from our information. The information given does not release the user from the obligation of own judgment and verification.

It must be remembered that our products are subject to a natural process of wear and aging.